

PLAN VIEW  
1/16"=1'-0"

- THE FOLLOWING DOORS ARE AVAILABLE AT EXTRA CHARGE:
- SINGLE PERSONNEL DOOR 3'-0"w x 7'-0"h (C/W 9'-5" HOOD)
  - DOUBLE PERSONNEL DOOR 6'-0"w x 7'-0"h (C/W 9'-5" HOOD)
  - SIDE SLIDING CARGO DOOR 19'-7"w x 14'-6"h
  - END SLIDING CARGO DOOR TOP 5'-9"w, BASE 10'-5"w x 14'-6"h

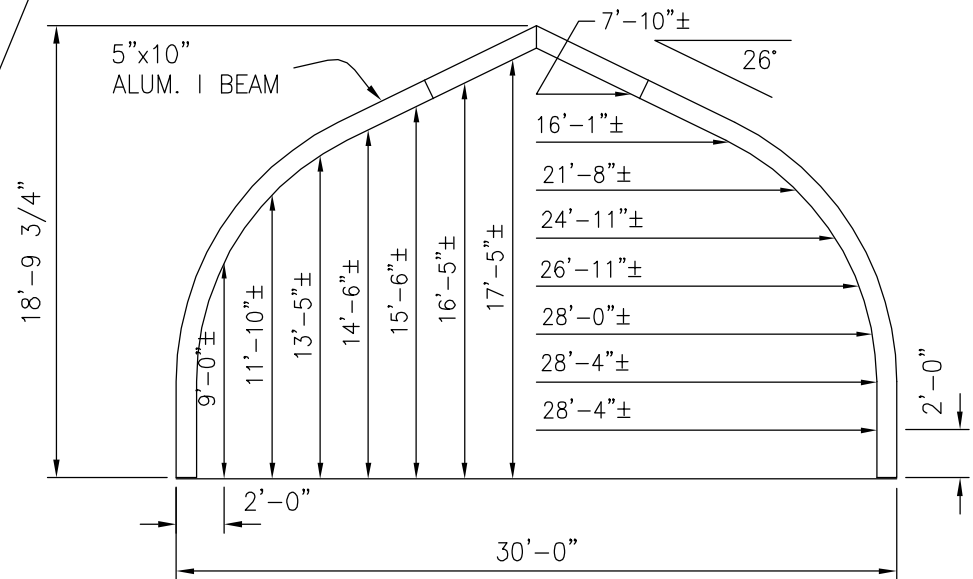

SECTION 30'-0" STRUCTURE  
1/8"=1'-0"

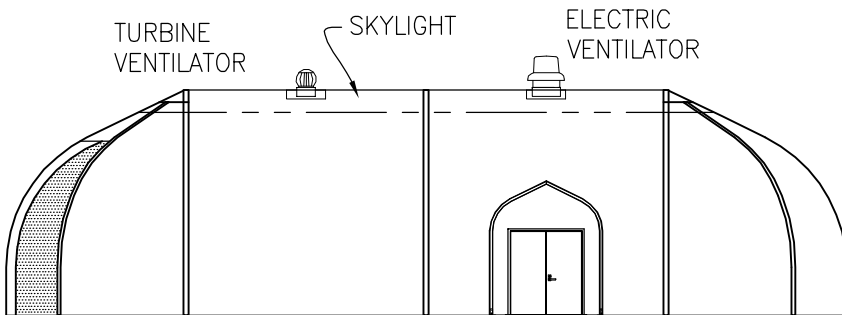

ELEVATION  
1/16"=1'-0"



SIGNATURE SERIES  
30'-0" WIDE  
STRUCTURE

DATE 11/16/2005 SCALE AS NOTED

DRAWING # S-30 (20'OC) IMPERIAL

SIGNATURE SERIES